



AX Series

INTELLIGENT IONIZATION DETECTOR



Unique Features:

- Patented XPerT Detector Base Addressing
- Built-in Dedicated Microprocessor
- Five Selectable Response/Sensitivity Modes
- Ten 7-Day Response/Sensitivity Mode Timers
- Built-in Manufactured Date Look-up
- Sub-Addressing of Ancillary Functions
- Dual-Alarm LEDs with 360° View

Description:

The low-profile Advanced Fire Systems **AX Series** Intelligent Ionization Detector, with built-in dedicated microprocessor, offers a wide range of capabilities to suit any commercial, industrial, or institutional application. Distinguished by its red dual-alarm LEDs which illuminate red during alarm, the detector provides a complete 360° view of device status. The detector's dual-alarm LEDs can also be programmed for flashing during quiescent mode.

The **AX Series** Intelligent Ionization Detector incorporates a unique industry method of addressing the detector. Each detector is individually addressed through its associated base by a patented address ("XPerT") card. The address is quickly and easily set by removing "pips" on the XPerT card according to a chart supplied with each base. Once the address is set on the XPerT card, it can be slid into place and locked into the detector base. By addressing the **AX Series** detector at the base rather than internally to the detector, the all-too-common errors associated with detector removal and maintenance are eliminated.

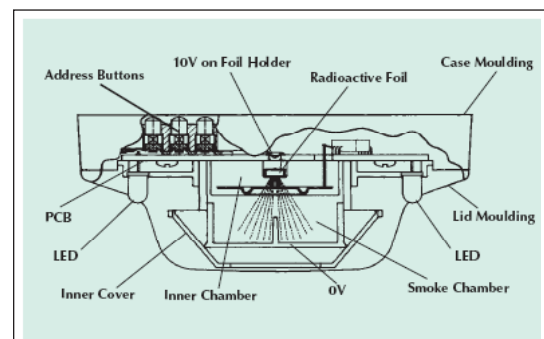

The **AX Series** Intelligent Ionization Detector contains an ionization chamber consisting of a reference chamber (inner chamber), with an Americium 241 radioactive source, inside a smoke chamber. In normal environmental air, the reference chamber irradiates the air in both chambers, producing positive and negative ions. Ions are attracted to the electrode of the opposite sign creating a small electric current flow between the electrodes. When smoke particles enter the smoke chamber, ions become attached to the smoke particles reducing the current flow through the chamber. This effect is greater in the smoke chamber than the reference chamber, and the imbalance causes the sensing electrode to become more positive, producing an analog alarm value which is transmitted to the **AX Series** Intelligent Fire Alarm Control Panel.

Features:

- UL 268 Listed
- Low-Profile Design
- Automatic Drift Compensation
- Automatic Detector Testing w/Maintenance Alert
- Certified Detector Sensitivity Testing
- Field Programmable Alarm Verification
- Sub-Addressable Remote LED Output *
- Optional Relay and Isolator Bases *
- Superior Rejection of Transient Signals
- Detector to Base Locking Mechanism
- Plastic Dust Cover for Construction Protection
- 100% Digital Communication Protocol



* Refer to **AX Series** Intelligent Detector Bases and Intelligent Isolator data sheets.

Product Data Sheet

Designed to adapt to changing environments and protect against unwanted false alarms, the response characteristics of the **AX Series** detectors have been carefully set to comply with the stringent requirements of UL 268 and NFPA 72. Each **AX Series** detector is continuously monitored and tested for proper sensitivity and operation. If a problem is detected with either the device's sensitivity or proper operation, a trouble or maintenance signal is reported back to the fire alarm control panel. In addition, the **AX Series** detector will compensate for any sensitivity drift of the initial programmed response/sensitivity value due to environmental contamination and/or dust buildup. Each detector will maintain the initially set sensitivity at a constant level even when the chamber is severely contaminated. When compensation levels exceed normal values, a maintenance signal will be generated.

In addition to the detector's superior false alarm reduction

Description Cont'd:

features, each **AX Series** detector is capable of being field programmed for one of five response/sensitivity modes (see *Table 1*). Response modes correspond to unique response behaviors of a detector and the type of environment it is protecting, which can be broadly related to the characteristics of a fire. The detector response modes relate to different combinations of smoke sensitivity characteristics and transient rejection/stabilization times (see *Table 2*). Response mode 1 is more sensitive than response mode 5. Detectors set to response mode 1 would be for environments in which sources of unwanted alarms are rare. Response mode 5 set detectors would be suitable for more dusty or smoky environments (i.e.: factory, light industry areas). Response mode 3 (default programmed) would be the mid-sensitivity level used for most normal ionization detector applications. Response mode setting and hysteresis of the individual detectors are stored within the detector's memory. The advantage of storing this critical information in the detector rather than in the fire alarm control panel software is that the detector will maintain the programmed response settings and compensated values even when power is removed from the detector. If the detector is powered down or inadvertently replaced in another location, the detector response mode and clean values are not lost, thereby minimizing the errors associated with inferior products; false alarms due to a dirty detector and non-calibrated response/sensitivity mode parameters.

Equally beneficial as the response mode settings, the **AX Series** detectors are each capable of being programmed for different response/sensitivity mode settings based on the time of day and day of week. Detectors can be set to one of ten 7-day response mode/sensitivity timers, allowing the detector to be more or less sensitive due to installation changing environments based on time of day and day of week. Such changing environments can be industrial, restaurant, or factory processes that produce smoke, fumes, or excessive dust during normal working hours.

Another unique industry feature of the Advanced Fire Systems **AX Series** Intelligent Ionization Detector, in conjunction with the **AX Series** Intelligent Fire Alarm Control Panel, is its ability to sub-address detector base ancillary functions. Each **AX Series** detector is capable of incorporating, based on optional **AX Series** base utilization, a remote LED and/or relay. When these options are utilized, the user is capable of sub-addressing each of these options (remote LED and/or relay) to activate independently of the **AX Series** detector. This provides 100% free programmability of the detector base outputs to meet the demanding requirements of today's installations. (For further explanation, refer to **AX Series** Intelligent Detector Bases and Intelligent Isolator data sheets).

Table 1 - Recommended Response Mode Settings

Hotel Rm Apartment					Office Hospital Ward Factory Light Industry					Warehouse Restaurant				
1	2	3	4	5	1	2	3	4	5	1	2	3	4	5
		✓	✓	✓			✓	✓	✓			✓	✓	

1, 2, 3, 4, 5 = Response/Sensitivity Modes
 ✓ = Mode Suitable for Installation

Table 2

Response Mode	Sensitivity Characteristics	Programmable Assessment Time
1	.60 %/ft	5 sec
2	.60 %/ft	30 sec
3	.65 %/ft	5 sec
4	.65 %/ft	30 sec
5	.70 %/ft	5 sec

Intelligent Ionization Detector Specifications	
Voltage	17-28 VDC
Modulation Voltage	5-9 VDC
Operating Current	
Quiescent	0.5 mA
Alarm	0.5 mA
w/LED's	5.5 mA
Surge Current	0.5 mA
Air Flow	0-300 ft/min
Sensitivity - Smoke	.88-2.09 %/ft
Environment	Indoor, Dry
Operating Temperature	32-120° F (0-48° C)
Humidity	10-93% (non-condensing)
Dimensions	4" x 1 7/8"
Weight	3.7 oz
Housing	Polycarbonate, 94 V0

Ordering Information	
AX-58000-550ADV	AX-ION Intelligent Ionization Detector
* Refer to AX Series Intelligent Detector Bases and Intelligent Isolator data sheets for specific information.	



100 South Street, Hopkinton, Massachusetts, USA MA 01748
 Tel: 1.508.453.9995 ■ Fax: 1.508.453.9996 ■ www.afsi.us.com